

NEET Like MOCK TEST-01

Time : 3.00Hrs

200 MCQs PATTERN

Max.Marks.720

INSTRUCTIONS

1. This test will be a 3 hours Test, Maximum Marks 720M.
2. This test consists of Physics, Chemistry, Botany and Zoology questions with equal weightage of 180 marks.
3. Each question is of 4 marks.
4. There are four parts in the question paper, consisting Part-I Physics (Q.no.1 to 50), Part-II Chemistry (Q.no.51 to 100), Part-III Botany (Q. no. 101 to 150) and Part-IV Zoology (Q. no.151 to 200). Each part is divided into two Sections, Section A consists of 35 multiple choice questions & Section-B consists of 15 Multiple choice questions, out of these 15 questions candidates can choose to attempt any 10 questions.
5. There will be only one correct choice in the given four choices for each question. For each question 4 marks will be awarded for correct choice, 1 mark will be deducted for incorrect choice and zero mark will be awarded for unattempted question.
6. Any textual, printed or written material, mobile phones, calculator etc. is not allowed for the students appearing for the test.
7. All calculations / written work should be done in the rough sheet provided.

Syllabus

Physics : CLASS XI & XII

Chemistry : CLASS XI & XII

Biology : CLASS XI & XII

PART-1 : PHYSICS : SECTION-A

- Calculate the momentum transferred to a surface when a radiation of energy E falls normally on it. Assume that the reflectivity of the surface is unity.
 - $\frac{E}{c}$
 - $\frac{2E}{c}$
 - Ec
 - $\frac{E}{c^2}$
- Taking the wavelength of first Balmer line in the hydrogen spectrum ($n = 3$ to $n = 2$) as 660 nm, then the wavelength of 2nd balmer line in the same spectrum ($n = 4$ to $n = 2$) will be
 - 488.9 nm
 - 388.9 nm
 - 889.2 nm
 - 642.7 nm
- A circular hole is cut from a disc of radius 6 cm in such a way that the radius of the hole is 1 cm and the centre of the hole is a distance of 3 cm from the centre of the disc. The distance of the centre of mass of the remaining part from the centre of the original disc is
 - $\frac{3}{35}$ cm
 - $\frac{1}{35}$ cm
 - $\frac{3}{10}$ cm
 - $\frac{7}{35}$ cm
- A uniform solid sphere A of mass 'm' is rolling without sliding on a smooth horizontal surface. It collides elastically and head – on with another stationary hollow sphere B of the same mass and radius. Assuming friction to be absent everywhere, the ratio of the kinetic energy of B to that of A just after the collision is

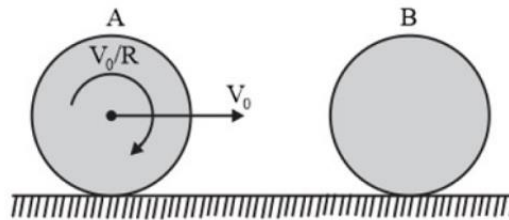

- 5:2
 - 1:1
 - 2:3
 - 3:2
- The magnitude of displacement vector of a particle which is moving in a circle of radius a with constant angular velocity ω as a function of time is
 - $2a \sin \omega t$
 - $2a \sin \frac{\omega t}{2}$
 - $2a \cos \omega t$
 - $2a \cos \frac{\omega t}{2}$
 - An ideal gas ($\gamma = 1.5$) is expanded adiabatically. How many times its initial volume should the gas be expanded to reduce the root mean square velocity of molecules by a factor of 2?
 - 4 times
 - 16 times
 - 8 times
 - 2 times
 - An electric field is applied to a semiconductor. Let the number of charge carries be n and the average drift speed be v . if the temperature is increased, then
 - both n and v will increase
 - n will increase and v will decrease
 - both n and v will decrease
 - n will decrease and v will increase
 - A battery is charged to a voltage of 15V for 8 hours with 10 A current. On discharge, the battery supplies a current of 5A for 15 hours at a mean terminal voltage of 14V. The efficiency of the battery is
 - 80%
 - 90%
 - 87.5%
 - 82.5%
 - Two concentric co – planar circular loops of radius R and ($r \ll R$) are placed as shown in the figure. The mutual inductance of the system will be

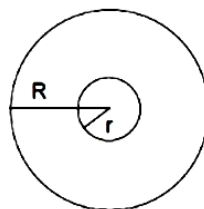

- $\frac{\pi\mu_0 r^2}{2R}$
- $\frac{\pi\mu_0 r^2}{4R}$
- $\frac{\pi\mu_0 R^2}{4r}$
- $\frac{\pi\mu_0 R^2}{2r}$

10. A transformer of frequency 60 Hz and 120 V input has 8:1 turn ratio. The frequency of the output is
 1) 40Hz 2) 480 Hz 3) 2 Hz 4) 60 Hz
11. A system consists of four equal charges $-Q$ placed at the four corners of a square and another charge q is placed at the centre of the square, then the value of q for which the system is equilibrium, is
 1) $-\frac{Q}{4}(1+2\sqrt{2})$ 2) $\frac{Q}{2}(1+2\sqrt{2})$ 3) $-\frac{Q}{2}(1+2\sqrt{2})$ 4) $\frac{Q}{4}(1+2\sqrt{2})$
12. There are two charged metallic spheres S_1 and S_2 of radii R_1 and R_2 respectively. The electric fields E_1 and E_2 on their surfaces are such that $E_1 / E_2 = R_1 / R_2$. Then the ratio V_1 / V_2 of their electrostatic potentials on each sphere is
 1) $\left(\frac{R_1}{R_2}\right)^3$ 2) $\frac{R_1}{R_2}$ 3) $\left(\frac{R_2}{R_1}\right)$ 4) $\left(\frac{R_1}{R_2}\right)^2$
13. There is an unknown quantity $x = R\left(\frac{l}{100-l}\right)$, here l is length (in cm) measured using a scale having least count of 1 cm, and R is a quantity known accurately. Find the percentage error in measurement of x for $l = 50\text{cm}$?
 1) 1% 2) 6% 3) 2% 4) 4%
14. On which quantity the escape velocity for earth does not depend on
 1) mass of the earth 2) mass of the projectile
 3) point of projection relative to the earth 4) gravitational constant
15. A simple pendulum is taken to 64 km above the earth's surface. Its new time period will
 1) increase by 1% 2) decrease by 1%
 3) increase by 2% 4) decrease by 2%
16. An iron wire AB has diameter of 0.6 mm and length 3m at 0°C . The wire is now stretched between the opposite walls of a brass casing at 0°C . What is the extra tension that will be set up the wire when the temperature of the system is raised to 40°C ?
 Given $a_{brass} = 18 \times 10^{-6} / \text{K}$, $a_{iron} = 12 \times 10^{-6} / \text{K}$, $Y_{iron} = 21 \times 10^{10} \text{ N} / \text{m}^2$

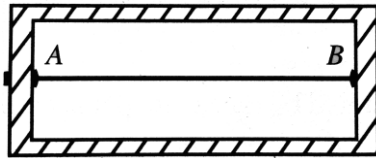

- 1) 14.2 N 2) 13.8 N 3) 16.3 N 4) 21.7 N
17. Two heat engines are operating in such a way that the heat rejected by the first engine is used as the heat input of the second. If both the engines are 40% efficient, then the overall efficiency of the system is
 1) 0.64 2) 0.8 3) 0.5 4) 0.9
18. The change in internal energy when 5 mole of hydrogen is heated to 20°C from 10°C is (specific heat of hydrogen at constant pressure is $8 \text{ cal} ((\text{mol}^\circ\text{C})^{-1})$)
 1) 200 cal 2) 350 cal 3) 300 cal 4) 475 cal
19. Find the amount of heat energy supplied to a Carnot engine from the source in each cycle if the engine is working between 300K and 600K and it has a work output of 800J per cycle.
 1) 800J 2) 1600J 3) 3500J 4) 6400J
20. A rectangular conducting loop carrying a current i_1 is situated near a long straight wire carrying a steady current i_2 . The wire is parallel to one of the sides of the loop and is placed in the same plane as that of the loop as shown in the figure. Then, the current loop will

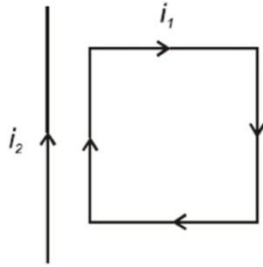

- 1) Move away from the wire
 2) Move towards the wire
 3) Remain stationary
 4) Rotate about an axis parallel to the wire
21. A compass needle free to turn in a horizontal plane is placed at the centre of a circular coil of 30 turns and radius 12cm. The coil is in a vertical plane making an angle of 45° with the magnetic meridian. The needle points west to east when the current in the coil is 0.35 A. the horizontal component of the earth magnetic field (in T) at that location is
 1) 3.9×10^{-5} 2) 3.9×10^{-6} 3) 5×10^{-5} 4) 2.6×10^{-5}
22. In ground to ground projectile motion under gravity, which of the following doesn't affect the time of flight?
 1) rotation of earth 2) air resistance 3) curvature of earth 4) all of these
23. The force exerted by the ideal string on the ideal pulley P shown in the figure is

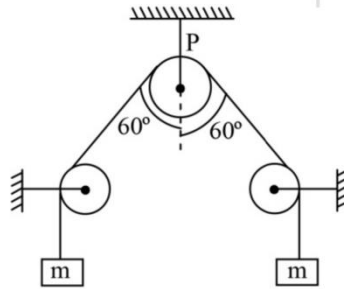

- 1) mg 2) $2mg$ 3) $\sqrt{2}mg$ 4) $4mg$
24. A boy of mass 50 kg is climbing a vertical pole at a constant speed. If coefficient of friction between his palms and the pole is 0.75, then the normal reaction between him and the pole is (take $g = 10m/s^2$)
 1) 700N 2) 625.67 N 3) 550 N 4) 666.67 N
25. An element of mass M has Z protons and N neutrons. Masses of proton and neutron are m_p and m_n respectively. Choose the correct relation among following options
 1) $M > Zm_p + Nm_n$ 2) $M = Zm_p + Nm_n$ 3) $M < Zm_p + Nm_n$
 4) M may be greater than, less than or equal to $Zm_p + Nm_n$ depending on nature of nucleus
26. The amplitude of a simple pendulum is 10cm. when the pendulum is at a displacement of 4 cm from the mean position, the ratio of kinetic and potential energies at that point is
 1) 5.25 2) 2.5 3) 4.5 4) 7.5
27. For a particle of mass m executing SHM with angular frequency ω , the kinetic energy 'k' is given by $k = k_0 \cos^2 \omega t$. The equation of its displacement can be
 1) $\left(\frac{k_0}{m\omega^2}\right)^{1/2} \sin \omega t$ 2) $\left(\frac{2k_0}{m\omega^2}\right)^{1/2} \sin \omega t$
 3) $\left(\frac{2\omega^2}{mk_0}\right)^{1/2} \sin \omega t$ 4) $\left(\frac{2k_0}{m\omega}\right)^{1/2} \sin \omega t$
28. Light of wavelength 3000\AA is incident on a metal surface whose work function is 1 eV. The maximum velocity of emitted photoelectrons will be
 1) $10ms^{-1}$ 2) 10^3ms^{-1} 3) 10^4ms^{-1} 4) 10^6ms^{-1}

29. When light of wavelength 300 nm or less falls on a photoelectric emitter A, photoelectrons are emitted. For another emitter B, light of wavelength 600 nm is sufficient for releasing photoelectrons. The ratio of the work function of emitter A to B is
 1) 1:2 2) 2:1 3) 4:1 4) 1:4
30. Flow rate of blood through a capillary of cross sectional area of 0.25 m^2 is $100\text{ cm}^3 / \text{s}$. The velocity of flow of blood is
 1) 1 mm/s 2) 0.2 mm/s 3) 0.3 mm/s 4) 0.4 mm/s
31. The surface tension of a thin liquid film formed between a U shaped wire and a light slider of length 30 cm supporting a weight of $1.5 \times 10^{-2} \text{ N}$ is

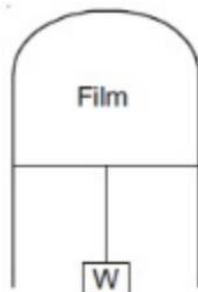

- 1) 0.0125 Nm^{-1} 2) 0.1 Nm^{-1} 3) 0.05 Nm^{-1} 4) 0.025 Nm^{-1}
32. A vessel contains oil (density 0.8 g/cc) over mercury (density 13.6 g/cc). a homogeneous sphere floats with half of its volume immersed in mercury and the other half is immersed in oil. The density of the material of the sphere in g/cc is
 1) 3.3 2) 6.4 3) 7.2 4) 12.8
33. If a piece of plane glass is placed on a word with letters of different colours, then the colour of the letter which will appear to be least raised is
 1) red 2) green 3) yellow 4) violet
34. If moment of inertia of disc about the diameter is given as I, then the moment of inertia of the same disc about an axis perpendicular to its plane and passing through its rim is
 1) $6I$ 2) $4I$ 3) $2I$ 4) $8I$
35. A uniform disc of mass 300kg is rotating freely about a vertical axis through its centre at a constant angular velocity ω_0 . A boy of mass 30 kg starts from the centre and moves along a radius to the edge of the disc. Angular velocity of the disc will now become
 1) $\frac{\omega_0}{6}$ 2) $\frac{\omega_0}{5}$ 3) $\frac{4\omega_0}{5}$ 4) $\frac{5\omega_0}{6}$

SECTION - B

36. A transistor is used as a common emitter amplifier with a load resistance of $2k\Omega$. The input resistance is 150Ω . Base current is changed by $20\mu\text{A}$ which results in change in collector current by 1.5 mA. The voltage gain of the amplifier is
 1) 900 2) 1000 3) 1100 4) 1200
37. If a LED forward biased, then
 1) electrons from the n – type side cross the p – n junction and recombine with holes in the p – type side
 2) electrons and holes neutralize each other in depletion region
 3) at junction electrons and holes
 4) none of these
38. Temperature at which the kinetic energy of gas molecule is half of the value of kinetic energy at 27°C is
 1) 13.5°C 2) 150°C 3) 75K 4) -123°C
39. When the temperature of metal sphere is increased by 40°C , its volume increases by 0.24%. The coefficient of linear expansion of the metal (in $^\circ\text{C}^{-1}$) is
 1) 2×10^{-5} 2) 6×10^{-5} 3) 2.1×10^{-5} 4) 1.2×10^{-5}

40. Dimensional formula of $\frac{a}{b}$ satisfying $P = \frac{a-t^2}{bx}$ where P is pressure, x is distance and t is time will be
- 1) MLT^{-1} 2) M^2LT^{-1} 3) MLT^{-2} 4) M^0L^{-1}

41. In Young's experiment, monochromatic light is used to illuminate the two slits A and B. Interference fringes are observed on a screen placed in front of the slits. Now if a thin glass plate is placed normally in the path of the beam coming from the slit, then which of the following explanation holds true with regards to fringes/fringe width?

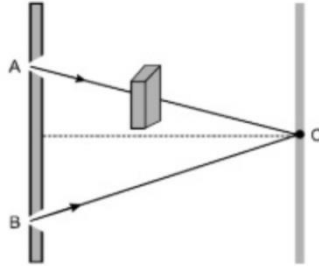

- 1) fringes will disappear 2) fringe width will decrease
 3) fringe width will increase
 4) there will be no change in the fringe width but fringe pattern will shift
42. An electromagnetic wave is propagating along the +z-axis. Direction of electric and the magnetic field of this wave can be represented by
- 1) $\vec{E} = E_0\hat{i}, \vec{B} = B_0\hat{j}$ 2) $\vec{E} = E_0\hat{k}, \vec{B} = B_0\hat{i}$
 3) $\vec{E} = E_0\hat{j}, \vec{B} = B_0\hat{i}$ 4) $\vec{E} = E_0\hat{j}, \vec{B} = B_0\hat{k}$
43. A wave of frequency 500Hz has a velocity of 350 m/s. The distance between two nearest points on the wave which are 60° out of phase with each other will be around
- 1) 70 cm 2) 0.7 m 3) 12.0 cm 4) 120.0 cm
44. A wave is represented by the equation given by $y = 7 \sin\left(7\pi t - 0.04\pi x + \frac{\pi}{3}\right)$ where x is in metres and t is in seconds. The speed of the wave is
- 1) 175 m/s 2) $49\pi m/s$ 3) $4.9\pi m/s$ 4) $0.28\pi m/s$
45. Work done by static friction on an object
- 1) may be positive 2) must be negative 3) must be zero 4) none of these
46. Three rods of identical geometry but different thermal conductivity are joined as shown. Temperature of the three ends are shown. Temperature of the junction is

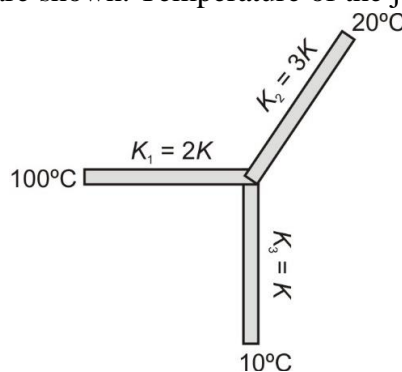

- (1) 35°C (2) 40°C (3) 45°C (4) 55°C
47. One mole of an ideal gas expands from initial state $(2T_0, V_0)$ to final state $(T_0, 2V_0)$. The process of expansion is given by $T = \left(-\frac{T_0}{V_0}V + 3T_0\right)$. Work done by the gas during the expansion is (T: temperature; V- Volume)

- 1) $RT_0 \ln 2$ 2) $3RT_0 \ln 2$ 3) $RT_0(3 \ln 2 - 1)$ 4) $T_0 V_0$

48. The efficiency of a heat engine increases by 20% when temperature of source is increased by 20% and temperature of sink is decreased by 20% simultaneously. The old efficiency of the engine is
 (1) 40% (2) 42.5% (3) 50% (4) 62.5%
49. In the arrangement for SHM shown, the horizontal ground is smooth and the coefficient of friction between the two blocks is μ . The time period of oscillation is T. The maximum amplitude of vibration so that the two blocks remain together is

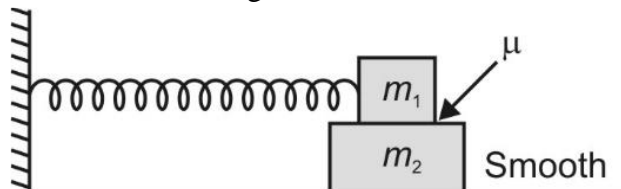

- 1) $\frac{\mu m_1 g T^2}{4\pi^2 m_2}$ 2) $\frac{2\pi\mu g}{T^2}$ 3) $\frac{\mu g T^2}{4\pi^2}$ 4) $\frac{\mu m_2 g T^2}{4\pi^2 m_1}$
50. A particle is executing SHM according to the relation $x = A \cos \omega t$. Average speed of the particle during time interval $0 \leq t \leq \frac{\pi}{6\omega}$
- 1) $\frac{3A\omega}{\pi}(2 - \sqrt{3})$ 2) $\frac{\sqrt{3}A\omega}{4}$ 3) $\frac{\sqrt{3}A\omega}{2}$ 4) $\frac{3A\omega}{\pi}$

PART-2 : CHEMISTRY

SECTION-A

51. pK_a of a weak acid (HA) and pK_b of weak base (BOH) are 3.2 and 3.4 respectively. The pH of their salt (AB) solution at 25°C is
 1) 6.9 2) 7.0 3) 1.0 4) 7.2
52. $\text{CH}_3\text{Br} \xrightarrow{\text{KCN}} \text{A} \xrightarrow[\text{LiAlH}_4]{4[\text{H}]} \text{CH}_3\text{CH}_2\text{NH}_2$
 IUPAC name of A is
 1) Methyl cyanide 2) Methyl isonitrile 3) Acetonitrile 4) Ethane nitrile
53. Which of the following exhibits greater coagulation power towards a negative colloid?
 1) ZnSO_4 2) Na_3PO_4 3) AlCl_3 4) $\text{K}_4[\text{Fe}(\text{CN})_6]$
54. Two half cells have reduction potentials -0.76 V and -0.13 V respectively. A galvanic cell is made from these two half cells. Which of the following statements is correct?
 1) Electrode of half-cell potential -0.76 V acts as cathode
 2) Electrode of half-cell potential -0.76 V acts as anode
 3) Electrode of half-cell potential -0.13 V acts as anode
 4) Electrode of half-cell potential -0.76 V acts as positive electrode and -0.13 V as negative electrode
55. What will happen when a block of copper metal is dropped into a beaker containing a solution of 1 M ZnSO_4 ?
 1) The copper metal will dissolve with evolution of oxygen gas
 2) The copper metal will dissolve with evolution of hydrogen gas
 3) No reaction will occur
 4) The copper metal will dissolve and zinc metal will be deposited
56. Electrometallurgical process is used to extract
 1) Fe 2) Pb 3) Na 4) Ni

57. The correct IUPAC name of the following compound is

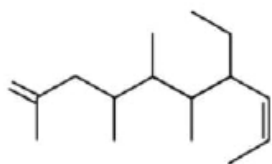

- 1) 7-Ethyl-2, 4, 5, 6 - tetramethyldeca-1, 8 - diene
 - 2) 4-Ethyl-5,6,7,9-tetramethyldeca-2,9-diene
 - 3) 2, 4, 5, 6 - tetramethyl-7-ethyldeca-1, 7-diene
 - 4) None of these
58. Which of the following sulphates has the highest solubility?
- 1) $BeSO_4$
 - 2) $MgSO_4$
 - 3) $BaSO_4$
 - 4) $CaSO_4$
59. In Clemmensen's reduction, the catalyst used is
- 1) Zn - Hg + Conc. HCl
 - 2) $NH_2NH_2 + C_2H_5ONa$
 - 3) $PdCl_2 / H_2O$
 - 4) $(C_6H_5)_3P + C_2H_5ONa$
60. The functional group which is formed when Phenol is made to react with Chloroform in the presence of dilute Sodium hydroxide
- 1) $-CH_2Cl$
 - 2) $-COOH$
 - 3) $-CHCl_2$
 - 4) $-CHO$
61. The compound formed when Ethyl bromide is heated with dry Silver oxide is
- 1) dimethylether
 - 2) diethylether
 - 3) Methylalcohol
 - 4) ethylalcohol
62. One mole of Ethylamine when reacts with nitrous acid will produce dinitrogen gas (at $0^\circ C$ and 1 atmospheric pressure) equal to
- 1) 22.4 L
 - 2) 1L
 - 3) 11.2 L
 - 4) 24.8 L
63. The correct statement about orthoboric acid is
- 1) It is a strong monobasic acid
 - 2) It is not a proton donor, but a weak Lewis acid
 - 3) It is a tribasic acid
 - 4) It is harmful for eyes
64. The energy required to remove an electron from the surface of sodium metal is 2.3 eV. What is the longest wavelength of radiation with which it can show photoelectric effect?
- 1) $5.4 \times 10^{-17} m$
 - 2) $5.4 \times 10^{-8} m$
 - 3) $5.4 \times 10^{-7} m$
 - 4) $5.4 \times 10^{-9} m$
65. If the dipole moment of Toluene and Nitro-benzene are 0.43D and 3.93D respectively, then what is the expected dipole moment of p-Nitrotoluene?
- 1) 3.50 D
 - 2) 2.18 D
 - 3) 4.36 D
 - 4) 5.30 D
66. Methanoic acid is heated with conc. H_2SO_4 to form
- 1) CO
 - 2) CO_2
 - 3) CH_4
 - 4) $(COOH)_2$
67. Glucose when treated with conc. HNO_3 gives
- 1) Acetic acid
 - 2) Saccharic acid
 - 3) Gluconic acid
 - 4) Sorbitol
68. Phenol associated in Benzene to a certain extent to form dimer. A solution containing $2.0 \times 10^{-2} kg$ of Phenol in 1.0 kg of benzene has its freezing point decreased by 0.69 K. The percentage of association of Phenol is (K_f for benzene = $5.12 K kg mol^{-1}$)
- 1) 73.4
 - 2) 50.1
 - 3) 42.3
 - 4) 25.1
69. The increasing order of the first ionization enthalpies of the elements B, P, S and F is
- 1) $B < S < P < F$
 - 2) $F < S < P < B$
 - 3) $P < S < B < F$
 - 4) $B < P < S < F$
70. When a NaCl is heated with sulphuric acid in the presence of MnO_2 a greenish-yellow gas liberated. The gas is
- 1) Cl_2
 - 2) NH_3
 - 3) N_2
 - 4) H_2
71. $C_5H_{10}O$ is a carbonyl compound. The number of carbonyl structural isomers possible for this molecular formula are
- 1) 5
 - 2) 8
 - 3) 6
 - 4) 7

72. In the reaction $4A + 2B + 3C \rightarrow A_4B_2C_3$, what will be the number moles of product formed, starting from one mole of A, 0.6 moles of B and 0.72 moles of C?
 1) 0.25 2) 0.3 3) 0.24 4) 2.32
73. The solubility of $\text{AgCl}(s)$ with solubility product 1.6×10^{-10} in 0.1 M NaCl solution would be
 1) $1.26 \times 10^{-5} M$ 2) $1.6 \times 10^{-9} M$ 3) $1.6 \times 10^{-11} M$ 4) $1.26 \times 10^{-15} M$
74. A non-stoichiometric compound $\text{Cu}_{1.8}\text{S}$ is formed due to the incorporation of Cu^{2+} ions in the lattice. What is the mole percentage of Cu^{2+} present in the compound?
 1) 88.88 2) 89.8 3) 63.5% 4) 11.11
75. At low pressure and high temperature, the Van der Waals equation is finally reduced (simplified) to
 1) $\left(p + \frac{a}{V_m^2}\right)(V_m - b) = RT$ 2) $p(V_m - b) = RT$
 3) $\left(p + \frac{a}{V_m^2}\right)V_m = RT$ 4) $pV_m = RT$
76. Zinc and hydrochloric acid react according to the following reaction:
 $\text{Zn}(s) + 2\text{HCl}(aq.) \rightarrow \text{ZnCl}_2(aq.) + \text{H}_2(g)$
 If 0.30 mole of Zn is added to 0.52 mole HCl, how many moles of H_2 is produced?
 1) 0.2 2) 0.62 3) 0.6 4) 0.26
77. In a reaction, $\text{Cr}_2\text{O}_7^{2-}$ is reduced to Cr^{3+} . What will be concentration of 0.1 M $\text{K}_2\text{Cr}_2\text{O}_7$ in equivalent per litre?
 $\text{Cr}_2\text{O}_7^{2-} + 14\text{H}^+ + 6e^- \rightarrow 2\text{Cr}^{3+} + 7\text{H}_2\text{O}$
 1) 0.9 N 2) 0.6 N 3) 0.3 N 4) 0.2 N
78. A gaseous mixture of 2 moles of A, 3 moles of B, 5 moles of C and 10 moles of D is contained in a vessel. Assuming that gases are ideal and the partial pressure of C is 1.5 atm, total pressure is
 1) 3 atm 2) 6 atm 3) 9 atm 4) 15 atm
79. In which of the following options chlorine will act as the best leaving group
 1) $\text{CH}_3 - \text{Cl}$ 2) $\text{CH}_3 - \text{CH}_2 - \text{Cl}$ 3) $\begin{array}{c} \text{CH}_3 \\ | \\ \text{H} - \text{C} - \text{Cl} \\ | \\ \text{CH}_3 \end{array}$ 4) $\begin{array}{c} \text{CH}_3 \\ | \\ \text{CH}_3 - \text{CH}_2 - \text{C} - \text{Cl} \\ | \\ \text{CH}_3 \end{array}$
80. A compound of vanadium chloride has spin only magnetic moment of 1.73 Bm. Its formula is
 1) VCl_2 2) VCl_3 3) VCl_4 4) VCl_5
81. The following equilibrium constants are given;
 $\text{N}_2 + 3\text{H}_2 \rightleftharpoons 2\text{NH}_3; K_1$
 $\text{N}_2 + \text{O}_2 \rightleftharpoons 2\text{NO}; K_2$
 $\text{H}_2 + \frac{1}{2}\text{O}_2 \rightleftharpoons \text{H}_2\text{O}; K_3$
 The equilibrium constant for the oxidation of 2 mole NH_3 by oxygen to give NO is
 1) $\frac{K_2 K_3^2}{K_1}$ 2) $\frac{K_2^2 K_3}{K_3}$ 3) $\frac{K_1 K_2}{K_3}$ 4) $\frac{K_2 K_3^3}{K_1}$
82. Which of the following will not show geometrical isomerism?
 1) $[\text{Co}(\text{ox})_3]^{3-}$ 2) $[\text{Co}(\text{en})_2\text{Cl}_2]\text{Cl}$ 3) $[\text{Cr}(\text{NH}_3)_4\text{Cl}_2]\text{Cl}$
 4) both $[\text{Co}(\text{en})_2\text{Cl}_2]\text{Cl}$ and $[\text{Cr}(\text{NH}_3)_4\text{Cl}_2]\text{Cl}$
83. For a reaction in which all reactants and products are liquids, which one of the following equations is most applicable?
 1) $\Delta H < \Delta E$ 2) $\Delta H = \Delta S$ 3) $\Delta H \approx \Delta E$ 4) Total W = 0

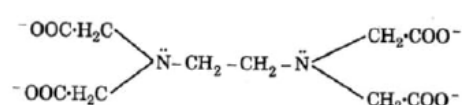
84. The void space in a primitive unit cell is:
 1) 48% void space 2) 24% void space 3) 96% void space 4) 50% void space
85. In chelate therapy, lead toxicity is removed by using the ligand
 COO^-
 1) CH_3COO^- 2) |
 COO^-
 3) AsO_4^{3-} 4) 

SECTION-B

86. The oxidation of SO_2 to SO_3 is an exothermic reaction. The yield of SO_3 will be maximum if:
 1) Temperature is increased and pressure is kept constant
 2) Temperature is reduced and pressure is increased
 3) Both temperature and pressure are increased
 4) Both temperature and pressure are reduced
87. Aqueous solution of 0.004 M Na_2SO_4 and 0.01 M glucose are isotonic. The percentage degree of dissociation of Na_2SO_4 is
 1) 85% 2) 75% 3) 60% 4) 25%
88. Which of the following statements regarding nitrogen pentoxide is not correct?
 1) Nitrogen pentoxide is a colourless, deliquescent liquid
 2) Nitrogen pentoxide is the anhydride of nitric acid
 3) In solid state it exists as NO_2^+ , NO_3^- ions
 4) The molecule of N_2O_5 is planar
89. Two different electrolytic cells filled with molten $Cu(NO_3)_2$ and molten $Al(NO_3)_3$ respectively are connected in series. When electricity is passed 2.7 g Al is deposited on electrode. Calculate the weight of Cu deposited on cathode.
 [Cu = 63.5; Al = 27.0 g mol⁻¹]
 1) 190.5 g 2) 9.525 g 3) 63.5 g 4) 31.75 g
90. Phenyl magnesium bromide reacts with methanol to give
 1) A mixture of anisole and Mg(OH)Br
 2) A mixture of benzene and Mg(OMe)Br
 3) A mixture of toluene and Mg(OH)Br
 4) A mixture of phenol and Mg(Me)Br
91. If ΔH_f° for H_2O_2 and H_2O are -188 kJ/mol and -286 kJ/mol, What will be the enthalpy change of the reaction:
 $2H_2O_2(l) \rightarrow 2H_2O(l) + O_2(g)$
 1) -196 kJ 2) -494 kJ 3) 146 kJ 4) -98 kJ
92. Which of the following statements is/are correct?
 i. Melting point of alkane increases with increase in number of C atoms and with increase in branching.
 ii. Boiling point of alkane increases with increase in number of C atoms but with decrease in branching.
 iii. Cycloalkanes have lower boiling point than normal alkane with same number of C atoms.
 iv. Alkenes have lower boiling point than same number of C atoms in alkanes.
 1) (I), (II) 2) (I), (II), (III) 3) (III), (IV) 4) (IV)
93. The binding energy of an element is 64 MeV. If Binding energy/nucleon is 6.4, then the number of nucleons are

- 1) 10 2) 64 3) 16 4) 6
94. Consider the following reaction in aqueous solution
 $5Br^-(aq) + BrO_3^-(aq) + 6H^+(aq) \rightarrow 3Br_2(aq) + 3H_2O(l)$
 If the rate of appearance of Br_2 at a particular time during the reaction is $0.025 M sec^{-1}$, what is the rate of disappearance (in $M sec^{-1}$) of Br^- at that time?
 1) $0.025 M sec^{-1}$ 2) $0.042 M sec^{-1}$ 3) $0.075 M sec^{-1}$ 4) $0.125 M sec^{-1}$
95. The rate constant (k') of one reaction is double the rate constant (k'') of another reaction. Then the relationship between the corresponding activation energies of the two reactions (E'_a and E''_a) will be-
 (Assume the pre-exponential factor & temperature to be same)
 1) $E'_a > E''_a$ 2) $E'_a = E''_a$ 3) $E'_a < E''_a$ 4) $E'_a < 4E''_a$
96. Which of the following is not a greenhouse gas?
 (1) CF_2Cl_2 (2) CH_4 (3) NO_2 (4) CO_2
97. Two liquids A and B are mixed in a ratio of 2 : 3. If $P_A^0 = 100$ mmHg and $P_B^0 = 300$ mmHg, then the mole fraction of A in vapour phase will be
 (1) 2/11 (2) 2/5 (3) 3/5 (4) 10/11
98. Reduction electrode potential of hydrogen electrode having pH = 4 will be
 (1) 0.236 V (2) -0.236 V (3) -0.059V (4) 0.059 V
99. If aqueous solution of $CuCl_2$ is electrolysed by 9.65 A current for 1000 seconds then mass of Cu liberated is (Atomic mass of Cu = 63.5 u)
 (1) 0.635 g (2) 6.35 g (3) 0.3175 g (4) 3.175 g
100. If, at t = 30 sec, $[A] = 100$ moles/L,
 at t = 40 sec, $[A] = 80$ moles/L,
 at t = 50 sec, $[A] = 64$ moles/L
 For a reaction, $A \rightarrow B$, the order will be
 (1) 1 (2) 2 (3) 3 (4) Zero

PART-3 BOTANY.

SECTION-A

101. Androecium and gynoecium are _____ of a flower.
 1) Essential whorls 2) Accessory whorls 3) Non – essential whorls 4) All of these
102. E.coli with completely N^{15} DNA was allowed to replicate in N^{14} medium for two generations. Percentage of bacteria with heavy DNA will be
 1) 6.25% 2) 50% 3) 25% 4) 100%
103. The asexual spores are generally not found in
 1) Basidiomycetes 2) Ascomycetes
 3) Deuteromycetes 4) Zygomycetes
104. The cells of the embryo sac in the chalazal end are called as
 1) Antipodal cells 2) Synergids 3) Egg and synergids 4) Antipodals and synergids
105. Which one of the following organisms possesses characteristics of both a plant and an animal?
 1) Mycoplasma 2) *Paramecium* 3) Bacteria 4) *Euglena*
106. Sticky pollen grains with large and attractive coloured flowers is characteristic of flower showing
 1) Anemophily 2) Entomophily 3) Hydrophily 4) malacophily
107. The *Pneumococcus* experiment of Griffith proves that
 1) DNA is the transforming principle
 2) Bacteria undergo binary fission
 3) Bacteria do not reproduce sexually
 4) RNA sometimes controls the production of DNA and proteins

- 2) It helps in the entry of pollen tube into a synergid
 3) It prevents entry of more than one pollen tube into the embryo sac
 4) It guides pollen tube from a synergid to egg.
119. Which of the following sets of bacteria are found to be very useful in genetic engineering experiments?
 1) *Nitrosomonas* and *Klebsiella*
 2) *Rhizobium* and *Diplococcus*
 3) *Nitrobacter* and *Azotobacter*
 4) *Escherichia* and *Agrobacterium*
120. Which one of the following traits of garden pea is a recessive feature?
 1) Round seed shape 2) Axial flower position
 3) Green seed colour 4) Green pod colour
121. Hydrolysis of nucleic acid yields
 1) Only sugar 2) Phosphoric acid only
 3) Nitrogenous base only 4) Nitrogenous base, sugar and phosphate
122. Read the following statements:
 i) presence of DNA
 ii) presence of cristae
 iii) presence of the 70S ribosome
 iv) Enzyme for carbohydrate synthesis
 v) site for oxidative phosphorylation
 How many of the above statements are in common for mitochondria and chloroplast?
 1) Two 2) Five 3) Three 4) Three
123. Which of the following statements is correct with respect to Blackman's law of limiting factor?
 1) only one factor can be limited in photosynthesis
 2) photosynthesis consists of a light and dark reaction
 3) the trapping of light by chloroplast is temperature dependent
 4) the trapping of light by chloroplast can occur only if CO_2 is present
124. Stirred – tank bioreactors have been designed for:
 1) Addition of preservatives to the product
 2) Purification of the product
 3) Ensuring anaerobic condition in the culture vessel
 4) Availability of oxygen throughout the process
125. The enzyme nitrogenase is
 1) A Cu – Fe protein 2) Found in prokaryotes only
 3) An O_2 requiring enzyme 4) Essential to convert NH_3 to N_2
126. The plant group that produces spores and embryo but lacks vascular tissues and seeds is
 1) Pteridophyta 2) Rhodophyta 3) Bryophyta 4) Phaeophyta
127. There are two plants A and B with respective critical photoperiod of 13 hours and 11 hours. When they are exposed to light for a period of 12 hours, it initiated flowering in both. Which of the following conclusions is most appropriate for these plants?
 1) Both Plant A and B are long day plants
 2) Both plant A and B are short day
 3) Plant A is short day plant and plant B is long day plant
 4) Plant A is long day plant and plant B is short day plant
- 128.

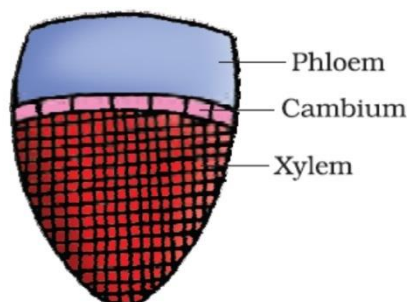

- 2) Except for the lower internode, other internodes are condensed forming a broad base called thalamus
- 3) The flower may develop in the axis of a small leaf – like structure called bract.
- 4) All of the above
145. How many microspore mother cells will give rise to 256 microspores after reduction division?
1) 512 2) 128 3) 64 4) 96
146. C₄ acid is converted into C₃ acid and vice-versa in sugarcane leaf, respectively in
1) Mesophyll and mesophyll cell 2) Mesophyll and bundle sheath cell
3) Bundle sheath cell and mesophyll cell 4) Mesophyll lysosomes and mesophyll chloroplast
147. Total number of ATPs produced during aerobic respiration of one glucose molecule is
1) Ten 2) Thirty eight 3) Twenty eight 4) Thirty
148. Select the incorrect statement w.r.t. plant growth regulators.
1) 2, 4-D (2, 4-dichlorophenoxyacetic acid) is a synthetic auxin
2) Spraying sugarcane crop with gibberellins increases the length of the stem
3) Cytokinins promote the apical dominance
4) Ethylene is a gaseous hormone
149. Choose the incorrect match.
1) Nucleoside : Adenosine, uridine
2) Nucleotide : Uridylic acid, cytidylic acid
3) Nucleic acid : DNA, RNA
4) Pyrimidines : Adenine and Guanine
150. During transcription, RNA polymerase binds to region ___(i)___ and uses substrate as ___(ii)___ to polymerise in template dependent fashion.
(i) (ii)
1) Intron Nucleoside triphosphate
2) Promotor Nucleoside monophosphate
3) Promotor Nucleoside triphosphate
4) Structural Nucleoside monophosphate

PART-4 ZOOLOGY.

SECTION-A

151. Given below are four methods and their mode of action in achieving contraception. Find the incorrect match.
1) Cervical caps – Prevent sperms reaching cervix
2) periodic abstinence – Natural method that avoids chances of ovum and sperms meeting.
3) Cu 375 – Suppress sperm motility and fertilizing capacity of sperms
4) Saheli – prevent ovulation
152. Snakes and lizards shed their scales as skin cast. It is
1) Dermis 2) Epidermis 3) Cornified cells 4) None of these
153. Hyposecretion of steroid hormones from adrenal glands leads to
1) Addison's disease 2) Cushing's disease 3) Dwarfism 4) None of the above
154. Which one of the following pairs of food components in humans reaches the stomach totally undigested?
1) Protein and starch 2) Starch and fat 3) Fat and cellulose 4) Starch and cellulose
155. Three levels of biodiversity are
1) Genetic diversity, species diversity and ecological diversity
2) Species diversity, ecological diversity and habitat diversity
3) Geographical diversity, genetic diversity and habitat diversity
4) Ecological diversity, species diversity and community diversity

156. In ECG the repolarization of ventricles is indicated by
 1) P wave 2) QRS complex 3) S wave 4) T wave
157. Species with small world populations that are not endangered or vulnerable at present, but are at the risk are called
 1) Critically endangered 2) Lower risk
 3) Rare 4) Extinct
158. Emulsification of fat is carried out by
 1) Pancreatic juice 2) HCl 3) Bile 4) Mucus of intestine
159. Darwin's finches are an excellent example of
 1) Adaptive radiation 2) Seasonal migration 3) Brood parasitism 4) Connecting links
160. In Mongolism, each cell has how many chromosomes
 1) 21st pair having one less 2) 23rd pair with one less
 3) 45 4) 47
161. The posterior lobe of the pituitary is called
 1) Glandularhypopysis 2) neurohypophysis 3) Adenohypophysis 4) Vascularhypophysis
162. Which of the following statement is/are correct with respect to remedy for plastic waste?
 A. Polyblend is a fine mixture of recycled modified plastic
 B. It is a zero – waste procedure.
 C. It was due to the collaboration of town people of Arcata and biologists of Humboldt State University.
 D. A blend of polyblend and bitumen enhances bitumen's water – repellent properties and helps to increase road life.
 1) A and B 2) A and C 3) A and D 4) Only A
163. How many statements are correct?
 a. Biomagnification is the natural ageing of a lake by nutrient enrichment of its water
 b. After CFC, methane is a major cause of greenhouse effect
 c. Ozone is a secondary pollutant in troposphere
 d. The thickness of the ozone is measured in Dobson unit
 1) a,b 2) only d 3) c, d 4) a,b,c
164. In mammals growing oocytes are surrounded by special nutritive cells called
 1) Follicle cells 2) Nurse cells
 3) Follicle cells and nurse cells 4) None of the above
165. The number of occital condyles in man is/are
 1) one 2) two 3) three 4) four
166. According to Hardy – Weinberg's principle, if allele one is denoted as 'A' and allele two as 'a' and their frequencies are denoted by p and q, and if random mating occurs. The frequency of heterozygous individual would be :
 1) 2pq 2) q^2 3) pq 4) p^2
167. Multiple alleles control the inheritance of
 1) Phenylketonuria 2) Colour blindness 3) Sickle cell anaemia 4) Blood groups
168. If the birth rate is 100, the death rate is 10 and the number of individuals in a population group is 1000, then what will be the intrinsic rate of natural increase of the population?
 1) 900 2) 90 3) 1090 4) 890
169. Genetically engineered bacteria have been successfully used in the commercial production of
 1) Human insulin 2) Testosterone 3) Thyroxine 4) Melatonin
170. At the neuromuscular junction:
 1) The muscle membrane possesses musculariae receptors.
 2) The motor nerve endings secrete norepinephine.
 3) Curare leads to prolongation of neuromuscular transmission
 4) The motor nerve endings secrete acetylcholine
171. Which one of the following is associated with excretion in amoeba?
 1) Endoplasm 2) Mitochondria 3) Contractile vacuole 4) plasma membrane
172. Peripatus is known as a connecting link because it has the characteristics of both
 1) Aves and Fishes 2) Reptiles and Birds 3) Fishes and Amphibians 4) Arthropods and Annelids

173. Caffeine, amphetamines and cocaine are:
 1) nerve depressants 2) nerve initiators 3) nerve stimulants 4) nerve impulse initiators
174. ADH is synthesized by _____ released by _____ and acts on _____
 1) Hypothalamus, neurohypophysis, PCT
 2) Hypothalamus, neurohypophysis, DCT and collecting duct
 3) Hypothalamus, adenohypophysis, PCT
 4) Hypothalamus, denohypophysis, loop of Henle
175. Which of the following statements is correct for the nodes of Ranvier' in nerves?
 1) neurilemma is discontinuous
 2) Myelin sheath is discontinuous
 3) Both neurilemma and myelin sheath are discontinuous
 4) Covered by myelin sheath
176. HIV causes reduction in
 1) T – helper cells only 2) All T – cells
 3) B – cells only 4) Both B and T – cells
177. Which of the following is incorrect about Klinefelter's syndrome?
 1) A chromosomal disorder 2) Karyotype of 44 + XXY
 3) Gynaecomastia 4) Fertile males
178. Residual volume is
 1) Lesser than tidal volume 2) Greater than inspiratory volume
 3) Greater than vital capacity 4) Greater than tidal volume
179. The rupture of the Graafian follicle and the release of ovum occurs under the influence of
 1) LH 2) FSH 3) MSH 4) GH
180. A lake with an inflow of domestic sewage rich in organic waste may result in
 1) Drying of the lake very soon due to algal bloom
 2) An increased production of fish due to lot of nutrients
 3) Death of fish due to lack of oxygen
 4) Increased complexity of the aquatic food web
181. Contraction of diaphragm during inhalation
 1) It decreases the volume of the thoracic chamber in the anteroposterior axis
 2) It increases the volume of the thoracic chamber in the dorso – ventral axis.
 3) It increases the volume of the thoracic chamber in the anteroposterior axis
 4) It decreases the volume of the thoracic chamber in the dorso – ventral axis
182. Which of the following is a pair of bacterial diseases?
 1) Typhoid and Pneumonia 2) Malaria and AIDS
 3) Ringworm and AIDS 4) Common cold and Malaria
183. In a medicolegal case of accidental interchange between two babies in a hospital, the baby of the blood group –A could not be rightly given to a couple with
 1) Husband of O group and wife of AB group
 2) Husband of A group and wife of O group
 3) Husband of B group and wife of O group
 4) Husband of AB group and wife of A group
184. Which of the following statement is incorrect w.r.t class cyclostomata?
 1) All the members are ectoparasites on some fishes
 2) Their body is devoid of scales and paired fins
 3) Circulation is of open type
 4) They are marine but migrate for spawning to fresh water

185. A type of granulocyte (i) and agranulocyte (ii) are phagocytic cells that destroy foreign organisms entering the body. (iii) secrete histamine, serotonin, heparin, etc., and are involved in inflammatory reactions. (iv) resist infections and are also associated with allergic reactions. (v) are responsible for the immune responses of the body.

1)

i)	ii)	iii)	iv)	v)
Monocytes	Neutrophils	Basophils	Eosinophils	Lymphocytes

2)

i)	ii)	iii)	iv)	v)
Neutrophils	Monocytes	Basophils	Eosinophils	Lymphocytes

3)

i)	ii)	iii)	iv)	v)
Neutrophils	Monocytes	Eosinophils	Basophils	Lymphocytes

4)

i)	ii)	iii)	iv)	v)
Monocytes	Neutrophils	Eosinophils	Basophils	lymphocytes

SECTION-B

186. Which of the following statement about human population is correct?

- 1) The world population was around 7.2 billion by 2000.
- 2) India's population reached close to 1.2 billion by 2000.
- 3) India's population was approximately 350 million at the time of independence
- 4) According to the 2011 census report, the population growth rate was more than 2 percent.

187. Which of the following tissue originates exclusively from the Ectoderm of the Embryo?

- 1) Epithelial tissue
- 2) Muscular tissue
- 3) Connective tissue
- 4) Nervous tissue

188. The main function of lacteals in the villi of human small intestine is the absorption of

- 1) Glucose & vitamins
- 2) Amino acids & glucose
- 3) Fatty acids & Glycerol
- 4) Water and Mineral salts

189. Sertoli cells are mousishing cells in the testis. They also secrete a hormone. Identify the same

- 1) Testosterone
- 2) Gonadotropin
- 3) Inhibin
- 4) Relaxin

190. Coronary heart disease is due to

- 1) Weakening of the heart valves
- 2) Insufficient blood supply to the heart muscles
- 3) Streptococcal bacteria
- 4) Inflammation of pericardium

191. Match column-I with column-II and select the correct option.

Column-I

A. Catalytic converter

B. Electrostatic precipitator

C. Ear muffs

D. Land fills

Column-II

I. Particulate matter

II. Carbon monoxide and precipitator nitrogen oxides

III. High noise level

IV. Solid wastes

(1) A – I, B – II, C – III, D – IV

(2) A – II, B – I, C – III, D – IV

(3) A – IV, B – III, C – II, D – I

(4) A – III, B – II, C – IV, D – I

